

SCREWED END 1-PC HEXAGONAL REDUCED PORT BALL VALVE V – 1H TYPE 1/4" ~ 2"



BAR STOCK/INVESTMENT CASTING STAINLESS STEEL/CARBON STEEL SCREWED END

FEATURES:

- Pipe thread in accordance with ANSI B2.1, BS 21 1973, DIN 259/2999, ISO 228
- Blow-out proof stem
- 1000 PSI (69 Bar) / 2000 PSI (138 Bar) W.O.G.
- Material : ASTM-A351 – CF8M, ASTM-A351-CF8;A1018

OPTION : Polished Surface
(Stainless Steel only)

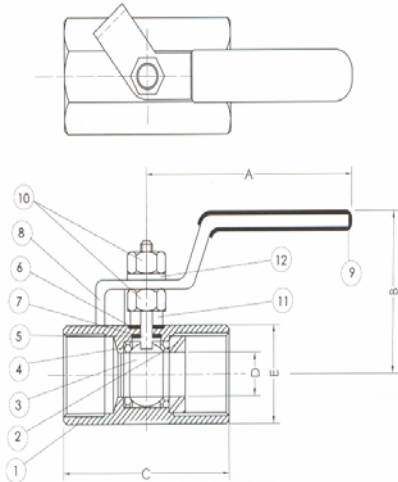

ITEM	PARTS	MATERIALS		
1	BODY	A1018	WCB	CF8M
2	INSERT	A1018	WCB	SUS 316
3	BALL	SUS 316	SUS 316	SUS 316
4	SEAT	15% R-PTFE	15% R-PTFE	15% R-PTFE
5	STEM	SUS 316	SUS 316	SUS 316
6	THRUST WASHER	PTEE	PTEE	PTEE
7	STEM SEAL	PTEE	PTEE	PTEE
8	HANDLE	SUS 304	SUS 304	SUS 304
9	HANDLE SLEEVE	PLASTIC	PLASTIC	PLASTIC
10	NUT	SUS 304	SUS 304	SUS 304
11	WASHER	SUS 304	WCB	SUS 304
12	SPRING WASHER	SUS 304	SUS 304	SUS 304

DIMENSIONS						UNIT : mm
Nominal Size	A	B	C	D	E	KGS
1/4"	66	38	39.4	5	17.5	0.12
3/8"	78	32.6	44	7.2	21.2	0.15
1/2"	108	62	56.7	9	29	0.33
3/4"	108	64.5	65.3	12.5	34.8	0.43
1"	108	63	76.5	15	41	0.63
1-1/4"	145	80.5	91.7	20	54.5	1.42
1-1/2"	145	80.5	98.5	25	57.9	1.45
2"	151	92	114.5	32	72.9	2.6